

T1400-1 and T1400-2

Jetting Only and Hybrid Jet/Chain
Cutting Trenching Systems



The **T1400-1** and **T1400-2** trenching systems have the capability to perform Jet trenching in soils of up to 100 KPA and mechanical chain cutting of soils of up to 250 KPA.



The T1400-1 and T1400-2 systems comprise a trenching vehicle consisting of a common trenching module with a customized launch and recovery system (LARS) rated at Lloyds sea state 6, which may be configured as either a tracked Jet Trenching only vehicle or alternatively configured to Hybrid Jet / Chain Cutting mode.

In Jet Trenching only mode, the T1400-1 and T1400-2 systems have 1050kW (1400hp) of available power, 750kW of this power is via variable speed drivers (VSD) electric motors with direct drive high pressure water pumps. In addition, low pressure backwash is delivered by the means of 2 x 100kW hydraulically driven water pump.

The Jetting tools have twin-legged parallel jet swords which are designed for Jet trenching up to 3 m in soil conditions ranging from 5 KPA to 100 KPA (using 2 m & 3 m jetting swords); and are capable of accommodating products up to 900 mm in diameter. The sophisticated Jetting systems also have the capability for backwashing, eduction and back filling of seabed material.

T1400-1 and T1400-2 trenching systems are illustrated when they are operated in the Hybrid Jet / Chain Cutting mode. In this mode the T1400-1 and T1400-2 system is configured with a 2 m x 400 mm chain cutter coupled with an instrumented cable bell mouth and depressor with a 3 m minimum bend radius (MBR) and two product-loading arms. In addition, a dedicated 375kW motor delivers low pressure direct drive water jetting to make it a true Hybrid Jet / Chain Cutting system. In this mode, the T1400-1 and T1400-2 systems have the capability to accommodate flexible products up to 250 mm diameter.

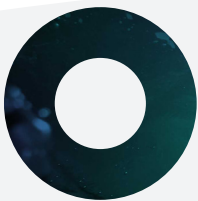

Experience

Helix Robotics Solutions operate a fleet of ROVs worldwide, seabed jet trenchers and several multi-purpose ROV and construction support vessels via strategic offices in key areas of the world.



Innovation

Helix Robotics Solutions works closely with our clients and vendors to seek and resolve complex technical developments to engineer practical solutions and implement in the most efficient, safe and economical ways possible.



Value

Helix Robotics Solutions is one of the most innovative and reliable specialty marine contractors in the world. Focusing on providing leading edge underwater, unmanned services in extreme environments, Helix strives to deliver the highest value to its customers.

TECHNICAL SPECIFICATIONS

Jetting Mode General Specification

Power	1050kW (1400 hp) 2 x 150kW Electro / Hyd HPUs driving multiple hydraulic pumps 2 x 375kW Variable speed drivers (VSD) electric motors directly driving high pressure water pumps
Operating depth	1,500 m
Max product diameter	900 mm
Max trench depth	3.0 m

Jetting Mode Dimensions

Length	7.8 m
Width	6.3 m with tracks
Height	5.5 m
Ground clearance	1.0 m
Weight in air	40 Te
Weight in water	0-15 Te

Jetting Mode Soil Strengths

Minimum soil bearing in tracked mode of 5 KPA
Capable of burial in soil strengths up 100 KPA @ 3 m depth
Pitch & Roll capability of +/- 15

Jetting Mode - Jetting System

Water supply	2 x 400kW direct drive water pumps Maximum flow 2300 m ³ /h Variable up to 15Bar
Configuration	Twin legged jet tool mounted on double scissor linkage
Jet swords	2 m & 3 m
Trench depth	Variable from 0 - 2 m or 3 m dependent on which swords are fitted.
Jetter internal	2 m swords - closed 200 mm to 900 mm max
Dimensions	3 m swords - closed 200 mm to 900 mm max

Jetting Mode - Educator / Backwash System

Configuration	Twin legged Educator / Backwash system with parallel function for constant angle backwash
Trench depth	Variable from 0 - 3.0 m
Trench width	200 mm - 900 mm
Eduction	Eduction 2 x 100kW Jet pump provides variable water supply to venture type pump

Hybrid Jet / Chain Cutting Mode General Specification

Power	450kW (600 hp) 1 x 375kW and 3 x 150kW Electro / Hyd HPUs driving multiple hydraulic pumps
Operating depth	1,500 m
Max product diameter	250 mm
Max trench depth	2.0 m x 400 mm

Hybrid Jet / Chain Cutting Mode Dimensions

Length	8.0 m
Width	6.3 m with tracks
Height	5.5 m
Ground clearance	0.5 m
Weight in air	40 Te
Weight in water	10 - 15 Te

Hybrid Jet / Chain Cutting Mode Soil Strengths

Minimum soil bearing in cutter mode of 12 KPA
Capable of burial in soil strengths up to 250 KPA @ 2 m depth
Pitch & Roll capability of up to +/- 15 degrees for both Jetting and Cutting

Chain Cutting Mode - Cutting System

Configuration	2 m long x 400 mm wide chain cutter driven by Hydraulic motor with product MBR of 3.0 m and bespoke depressor system
Power system	175kW HPU (150kW for Chain Cutter - 25kW for Spoil Removal)
Cable loading arms	2 x loading arms with 2000 kg lift capacity fully instrumented
Emergency product unload	Hot Stab to ROV Intervention panel
Spoil removal	Centrifugal dredge pump water flow 500m ³ /hr

Launch & Recovery System

Wide angle A frame c/w teleleg	40 Te SWL up to Sea State 6 Umbilical Snatch Limiter Submersible Cursor & Latching system Centralised A Frame & LARS Control Hut
Umbilical winch	c/w 1,800 m of Umbilical
LARS HPU	Open Frame 460kW HPU

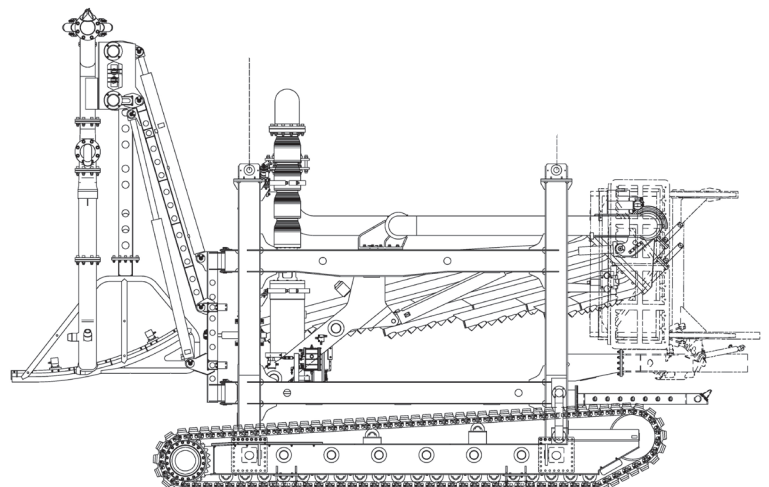
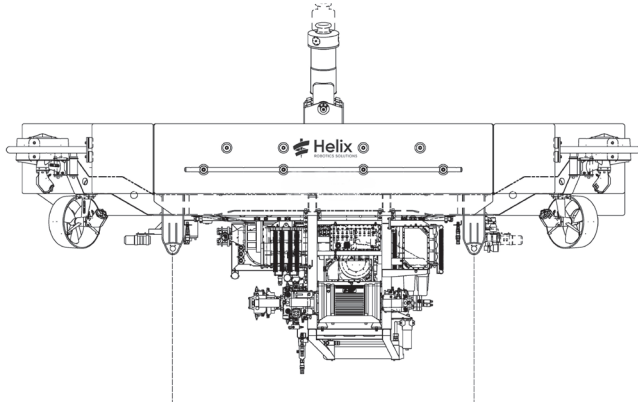
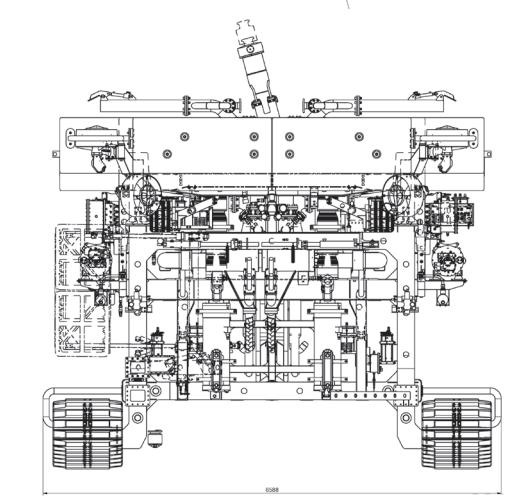
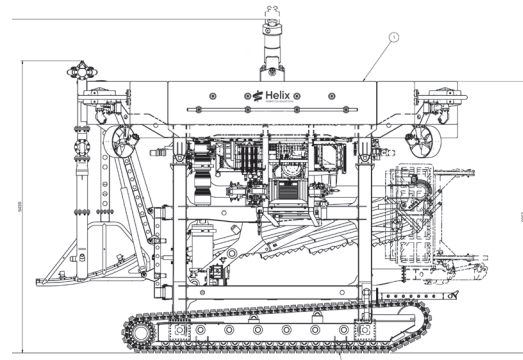
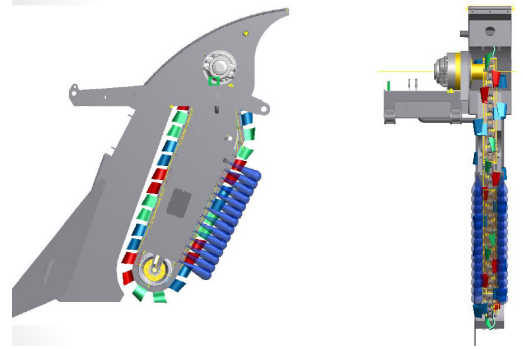



Corporate Headquarters

3505 W. Sam Houston
Parkway North
Suite 400
Houston, Texas
77043 USA

T (281) 618 0400

**Helix Robotics Solutions
(Europe/West Africa)**

Helix House, Kirkton Drive,
Pitmedden Industrial Estate,
Dyce, Aberdeen
AB21 0BG, UK

T +44 (0) 1224 351800

**Helix Robotics Solutions
(Asia Pacific)**

5 Loyang Crescent
Loyang Offshore Supply Base
Block 603, Tops Ave 6, Unit 1,
Box 5009 Singapore 508988

T +65 6501 0130